

Vacuum Pumps

Vacuum Pumps

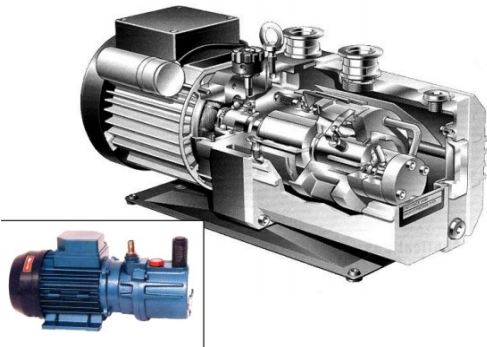

Vacuum pumps are devices conveying a defined volume of air from the suction to the exhaust areas thus creating depression. Electromechanical pumps are usually operated by an electrical motor but they can also be equipped with an internal combustion engine. They exploit the principle of operation of the compressor in the opposite direction, i.e. by sucking up air from a closed volume and letting it into the environment.

Construction Diagram Of The System

Construction Diagram Of The System

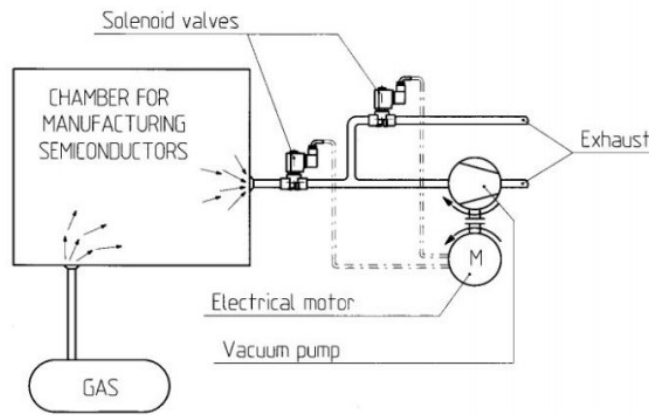

Solenoid Valve Application

Solenoid Valve Application

Electromechanical vacuum pumps usually operate on continuous duty and the requested level of vacuum is controlled by two solenoid valves positioned on the side of the vacuum. For example, in manufacturing semiconductors this system allows to stop the suction of air from the working chamber and divert it to a secondary way, thus keeping the requested vacuum conditions inside the chamber. In applications like this where the production of printed circuits requires a controlled atmosphere, inert gas is used. The gas enters the chamber per decompression. Therefore the system herewith described performs a safety function as well, preventing the gas from leaking outside.

Solenoid Valves Used

Solenoid Valves Used

TYPE 249



TYPE B297



TYPE 249

2/2 way NC direct acting solenoid valve with series 8 coils

TYPE B297

2/2 way NC direct acting solenoid valve with series 2 coils

We Recommend

We Recommend

Both recommended solenoid valves are suitable for this application. Viton is the apt seal material. Important: in case of applications with vacuum the valve should be positioned with the connection from where the medium usually flows out in the direction of the vacuum generating pump.