

D606/622 Series, Steam – 2/2 NC & RD606/622 Series, Steam – 2/2 NO

Specifications	
Function NC (single acting)	 <p>Flow direction overseat 1 → 2</p>
Function NO (single acting)	 <p>Flow direction overseat 1 → 2</p>
Maximum Viscosity	Max. 21cST (3 °E)
Body Material (Std)	Brass CW617N (EN 12165)
Orifice Material	Stainless Steel 1.4305 EN 10088 (AISI 303)
Flange Tube (Seamless)	Stainless Steel 1.4305 EN 10088 (AISI 303)
Plunger	Stainless Steel 1.4106 EN 10088 (AISI 430F)
Top Stop	Stainless Steel 1.4105 EN 10088 (AISI 430F)
Springs	Stainless Steel AISI 302
Seal Material (Std)	PTFE
Connection Type (Std)	G parallel thread (ISO 228-1)
Shading Ring	Copper
Electrical Characteristics	
Standard Coil Voltage DC (=)	12V, 24 V
Standard Coil Voltage AC 50 Hz (~)	24 V, 110 V, 200 V, 230 V
Standard Coil Voltage AC 60 Hz (~)	24 V, 120 V, 220 V, 240 V
Voltage Tolerance	+10% to -15% (AC)
	+10% to -5% (DC)
Duty Cycle	100% ED
Protection Class	IP65 (EN 60529) with plug and gasket correctly fitted *
Electrical Connection	to EN 175301 - 803 - A (ex DIN 43650)
Coil Insulation	Class H 180 °C
Power Rating (Standard)	AC 18 VA (holding) AC 36 VA (inrush) DC 14 W

Features and Benefits

- Direct Acting
- Robust construction for industrial applications
- Zero pressure rated
- Stainless steel AISI 430F operators with low residual magnetism
- Coils tested 100% in compliance to RoHS directive and to relevant international standards
- High quality seal material
- Response time 5 to 25 ms

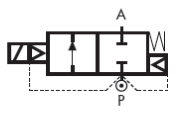
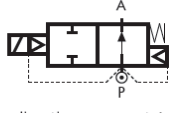

Pipe Size	Cv (gpm)	Kv (m³/h)	OPD (bar)		Orifice (mm)	Seal Material	Valve Code
			AC Voltages	DC Voltages			
¾"	8.42	7.20	1 - 9	1 - 9	24	PTFE	D606DIY
¾"	8.42	7.20	1 - 9	1 - 9	24	PTFE	D622DIY
1"	8.42	7.20	1 - 9	1 - 9	24	PTFE	RD606DIY
1"	8.42	7.20	1 - 9	1 - 9	24	PTFE	RD622DIY

Options Available

Valve Options (see coding chart)
NPT threads (minimum batch may be required)

Seal Material ¹ and Media Temperature Range	Media ²	Ambient Temperature Range	
		Min	Max
Filled PTFE (+80 °C ³ to +180 °C)	Steam	-10 °C	+70 °C

¹ See corrosion reference guide and sealing solutions for material compatibility.

² Water and high content of condensate can damage the diaphragm.

³ For a correct functioning, the minimum working temperature of the solenoid valve cannot be below +80 °C.

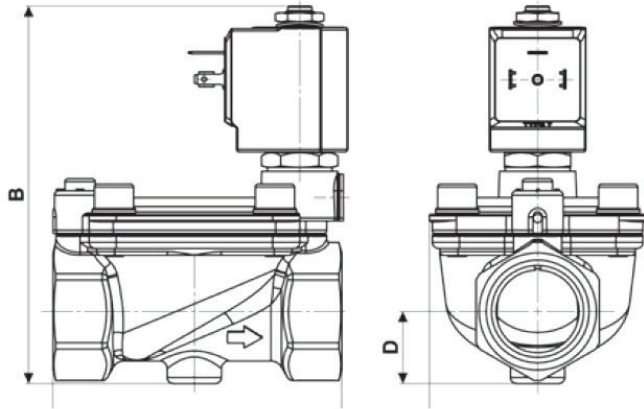
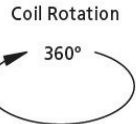

Preferred Valve Mounting Options



Pipe Size	A	B	C	D	Weight (kg)
3/4" - 1"	96	126	72	24	1.3

Dimensions (mm)

Solenoid enclosures

7--1 Type Coil - Insulation class H

- External material: PPS (glass fiber & mineral filled)
- Electrical connection: DIN EN 175301-803 form A
- Winding insulation: Class H (E180)
- Enclosure classification: Conforms to IP65 (according to EN 60529) with plug and gasket correctly fitted*



Type 600 011- Plug

- Rated Voltage (max.): 250 VAC / 300 VDC
- Nominal Current: 10A (rated) / 16A (max)
- Wire cross-section: 1.5 mm² max
- Cable Entry: PG9 (6 to 8 mm)
- Enclosure classification: Conforms to IP65 (according to EN 60529) with supplied gasket
- Insulation class: group C- VDE 0110
- Housing colour: black
- UL approved, file No: E205538



* Plug and gasket not supplied as standard, must be ordered separately.

Coding chart

Main Valve Assembly

Valve Type	
D	NC
RD	NO

Pipe Size	
06	3/4"
22	1"

Option	
N	NPT
	w/o option

Coil options

Voltage / Frequency - Class H	
7151	12 VDC
7251	24 VDC
7201	24 V / 50/60 Hz
7401	110 V / 50 Hz - 120 V / 60 Hz
7601	200 V / 50 Hz - 220 V / 60 Hz
7701	230 V / 50 Hz - 240 V / 60 Hz

Plug

Plug	
0A1	c/w plug
	w/o plug

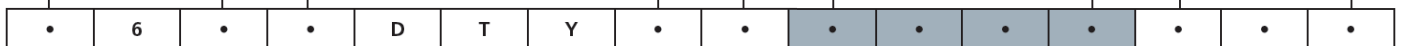

Product coding example:

D606DTY 7251
 3/4" G, auto operation, brass body, PTFE seals, 1.5 mm orifice, 24 VDC, without plug.