

RD362/363 Series, General Purpose – 3/2 Normally Open

Specifications	
Function (single acting)	 <p>Flow direction underseat 2 → 1</p>
Maximum Viscosity	Max. 21cST (3 °E)
Body Material (Std)	Brass CW617N (EN 12165)
Orifice Material	Stainless Steel 1.4305 EN 10088 (AISI 303)
Flange Tube (Seamless)	Stainless Steel 1.4305 EN 10088 (AISI 303)
Plunger	Stainless Steel 1.4106 EN 10088 (AISI 430F)
Top Stop	Stainless Steel 1.4105 EN 10088 (AISI 430F)
Springs	Stainless Steel AISI 302
Seal Material (Std)	Foodgrade FKM
Connection Type (Std)	G parallel thread (ISO 228-1)
Shading Ring	Copper
Electrical Characteristics	
Standard Coil Voltage DC (=)	24 V
Standard Coil Voltage AC 50 Hz (~)	24 V, 110 V, 200 V, 230 V
Standard Coil Voltage AC 60 Hz (~)	24 V, 120 V, 220 V, 240 V
Voltage Tolerance	+10% to -15% (AC)
	+10% to -5% (DC)
Duty Cycle	100% ED
Protection Class	IP65 (EN 60529) with plug and gasket correctly fitted *
Electrical Connection	to EN 175301 - 803 - A (ex DIN 43650)
Coil Insulation	Class H 180 °C
Power Rating (Standard)	AC 18 VA (holding) AC 36 VA (inrush) DC 14 W

Features and Benefits

- Direct Acting
- Robust construction for industrial applications
- Zero pressure rated
- Stainless steel AISI 430F operators with low residual magnetism
- Coils tested 100% in compliance to RoHS directive and to relevant international standards
- High quality seal materials
- Response time 5 to 25 ms

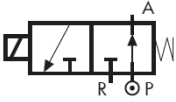

Pipe Size	Cv (gpm)	Kv (m³/h)	OPD (bar)		Orifice (mm)	Seal Material	Valve Code
			AC Voltages	DC Voltages			
¼"	0.09	0.08	0 - 16	0 - 13	1.5	FKM	RD363CVC
¼"	0.15	0.13	0 - 10	0 - 10	2.0	FKM	RD363CVE
¼"	0.24	0.20	0 - 7	0 - 7	2.5	FKM	RD363CVG
¼"	0.32	0.27	0 - 4	0 - 4	3.0	FKM	RD363CVH

Options Available

Valve Options (see coding chart)
Body threaded connection G 1/8"
NPT threads (minimum batch may be required)

Seal Material ¹ and Media Temperature Range	Media	Ambient Temperature Range	
		Min	Max
FKM (-10 °C to +130 °C)	Water, oil, air	-10 °C	+50 °C

¹ See corrosion reference guide and sealing solutions for material compatibility.

Coil Rotation

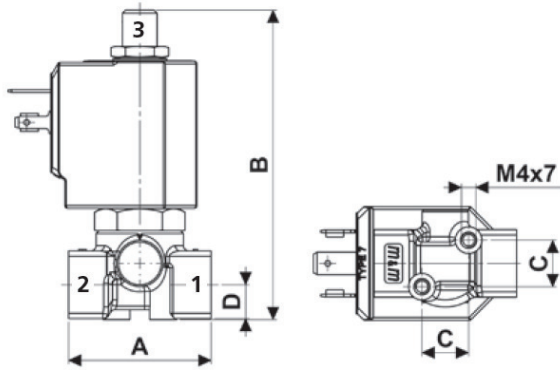

Preferred Valve Mounting Options



Pipe Size	A	B	C	D	Weight (kg)
1/8" - 1/4"	40	86.4	13	9.5	0.26

Dimensions (mm)

Solenoid enclosures

7--1 Type Coil - Insulation class H

- External material: PPS (glass fiber & mineral filled)
- Electrical connection: DIN EN 175301-803 form A
- Winding insulation: Class H (E180)
- Enclosure classification: Conforms to IP65 (according to EN 60529) with plug and gasket correctly fitted*



Type 600 011- Plug

- Rated Voltage (max.): 250 VAC / 300 VDC
- Nominal Current: 10A (rated) / 16A (max)
- Wire cross-section: 1.5 mm² max
- Cable Entry: PG9 (6 to 8 mm)
- Enclosure classification: Conforms to IP65 (according to EN 60529) with supplied gasket
- Insulation class: group C- VDE 0110
- Housing colour: black
- UL approved, file No: E205538



* Plug and gasket not supplied as standard, must be ordered separately.

Coding chart

Main Valve Assembly

Pipe Size
2 1/8"
3 1/4"

Orifice
C 1.5
E 2.0
G 2.5

Option
N NPT
w/o option

Coil options

Voltage / Frequency - Class H	
7251	24 VDC
7201	24 V / 50/60 Hz
7401	110 V / 50 Hz - 120 V / 60 Hz
7601	200 V / 50 Hz - 220 V / 60 Hz
7701	230 V / 50 Hz - 240 V / 60 Hz

Plug

Plug
0A1 c/w plug
w/o plug

RD	3	6	.	C	V
----	---	---	---	---	---	---	---	---	---	---	---	---	---	---	---	---

Product coding example:

RD362CVC 7251
1/8" G, auto operation, brass body, FKM seals, 1.5 mm orifice, 24 VDC, without plug.