

# WB251 Series, Dry Armature – 2/2 Normally Closed

Specifications	
Function (single acting)	
Maximum Viscosity	Max. 21cST (3 °E)
Body Material (Std)	Natural polysulphone FDA compliant (PSU)
Tube	Stainless Steel AISI 304
Flange	POM
Plunger	Stainless Steel 1.4105 EN 10088 (AISI 430F) or equivalent
Top Stop	Stainless Steel 1.4105 EN 10088 (AISI 430F)
Springs	Stainless Steel AISI 302
Seal Material (Std)	Silicone FDA compliant
Connection Type (Std)	See table
Shading Ring	Copper
Electrical Characteristics	
Standard Coil Voltage DC (=)	24 V
Standard Coil Voltage AC 50 Hz (-)	24 V, 110 V, 200 V, 230 V
Standard Coil Voltage AC 60 Hz (-)	24 V, 120 V, 220 V, 240 V
Voltage Tolerance	+10% to -15% (AC)
	+10% to -5% (DC)
Duty Cycle	100% ED
Protection Class	IP65 (EN 60529) with plug and gasket correctly fitted *
Electrical Connection	to industrial form B
Coil Insulation	Class F 155 °C
Power Rating (Standard)	AC 10 VA (holding) AC 16 VA (inrush) DC 10 W

## Features and Benefits

- Direct Acting
- Robust construction for industrial applications
- Zero pressure rated
- Stainless steel AISI 430F operators with low residual magnetism
- Coils tested 100% in compliance to RoHS directive and to relevant international standards
- High quality seal material
- Total separation between internal parts and medium
- Flow regulation screw as standard
- Flat gasket included (see drawing)
- Response time 5 to 25 ms

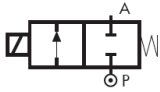

Connection Type	OPD (bar)		Orifice (mm)	Seal Material	Valve Code <sup>2</sup>
	AC Voltages	DC Voltages			
Ø 12 x L=35	0 - 0.07	0 - 0.05	9	Silicone	WB251DSS
	0 - 0.07	0 - 0.05	9	Silicone	WB251DSS1

<sup>2</sup> Product subject to phase-out, please contact sales office for availability.

NOTE: Vent pipe length for WB251DSS is 130 mm - vent pipe length for WB251DSS1 is 270 mm.

Seal Material <sup>1</sup> and Media Temperature Range	Media	Ambient Temperature Range	
		Min	Max
Silicone FDA compliant (-10 °C to +95 °C)	Water and beverages	-10 °C	+50 °C

<sup>1</sup> See corrosion reference guide and sealing solutions for material compatibility.

## How to use the flow chart

1. Select the required flow.
2. Note the corresponding pressure drop.
3. Based on where the two points intersect select the most appropriate model.

## Flow chart

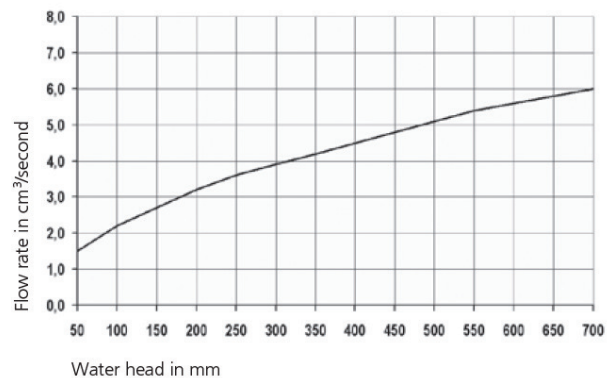

## Preferred Valve Mounting Options

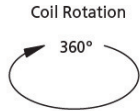

Flat gasket

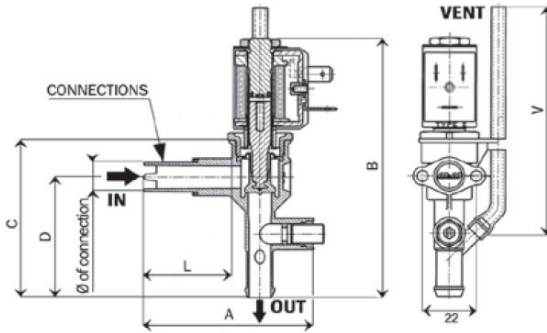
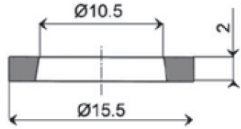

Valve Type	A	B	C	D	E	Weight (kg)
WB251DSS	70	108	65.5	50.2	95	0.175
WB251DSS1	70	108	65.5	50.2	235	0.175

Dimensions (mm)

## Solenoid enclosures

### 2--0 Type Coil - Insulation class F

- External material: PBT (reinforced fiberglass 30%)
- Electrical connection: Industrial form B
- Winding insulation: Class H (E180)
- Enclosure classification: Conforms to IP65 (according to EN 60529) with plug and gasket correctly fitted\*



### Type 600 001- Plug

- Rated Voltage (max.): 250 VAC / 300 VDC
- Nominal Current: 10A (rated) / 16A (max)
- Wire cross-section: 1.5 mm<sup>2</sup> max
- Cable Entry: PG9 (6 to 8 mm)
- Enclosure classification: Conforms to IP65 (according to EN 60529) with supplied gasket
- Insulation class: group C- VDE 0110
- Housing colour: black
- UL approved, file No: E205538



\* Plug and gasket not supplied as standard, must be ordered separately.

## Coding chart

### Main Valve Assembly

### Coil options

### Plug

Option	
-	tube 6 x 4 x 130mm
1	tube 6 x 4 x 270 mm

Voltage / Frequency - Class F (High Power DC only)	
22V0	24 VDC
2200	24 V / 50/60 Hz
2400	110 V / 50 Hz - 120 V / 60 Hz
2600	200 V / 50 Hz - 220 V / 60 Hz
2700	230 V / 50 Hz - 240 V / 60 Hz

Plug	
0B1	c/w plug
	w/o plug

WB	2	5	1	D	S	S	.	.	.	.	.	.	.	.
----	---	---	---	---	---	---	---	---	---	---	---	---	---	---

### Product coding example:

WB251DSS 22V0  
PSU body with vent pipe length 130 mm, auto operation, silicone seals, 24 VDC, without plug.