

EXPOSURE UNITS

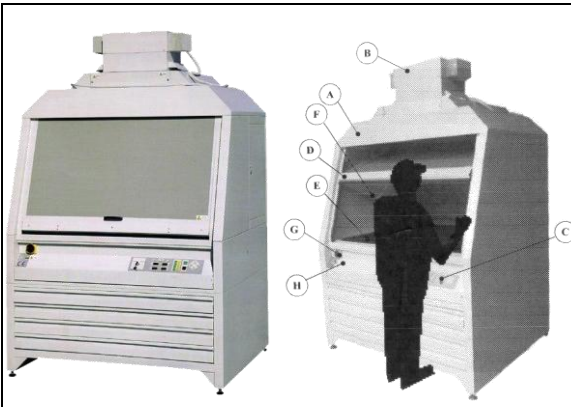

Exposure units are machines designed for the printing and silk-screening fields and used for exposing pre-sensitised aluminium plates. The machine works on images imprinted in films and reproduced on the plate. This is obtained by an intense emission of ultraviolet rays in the presence of vacuum at a pressure below the atmospheric pressure. The machine consists of a framework (A), a hood (B), a control panel (C), a glass holding frame (D), a fret worked carpet (E), a diffuser curtain (F), a main switch (G) and a vacuum circuit (H).

CONSTRUCTION DIAGRAM OF THE SYSTEM

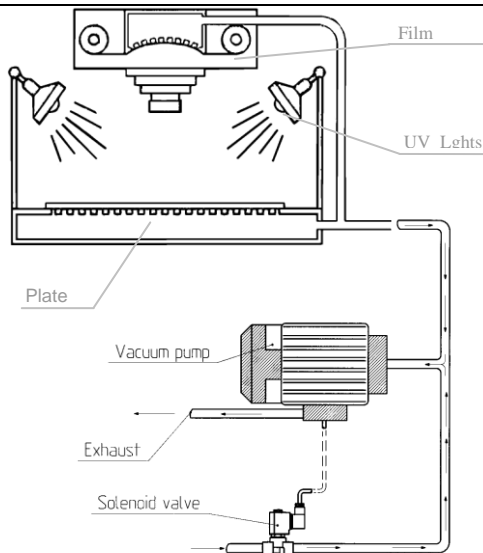

SOLENOID VALVE APPLICATION

An operator mans this machine by laying the plate on the carpet and, after closing the glass-holding frame, pushes the start button on the control panel. The exposure unit is equipped with a microprocessor to carry out the complete working schedule automatically: preheating of the lamp, pre-vacuum, vacuum, selection of the lamp power, main and secondary exposure, masking, switch-off of the lamp, re-establishment of the pressure. The solenoid valve and the vacuum pump are responsible for the cycle for creating vacuum inside the unit. When the pump is on the normally open solenoid valve is energized and closes the circuit keeping vacuum inside the unit. At the end of the exposure the pump stops and the solenoid valve is de-energized, opening the circuit to the outside and thus restoring the atmospheric pressure inside the unit.

SOLENOID VALVES USED



TYPE RD263DVH

2/2 way NO direct acting solenoid valve
with coils series 7 class H

WE RECOMMEND:

The recommended solenoid valve is normally open, robust and suitable for industrial use. This application does not require solenoid valves with large orifices because the time for the vacuum cycle depends on other functions.

Important: in case of applications with vacuum the valve should be positioned with the connection from where the medium usually flows out in the direction of the vacuum generating pump.