

# FOAM MARKERS

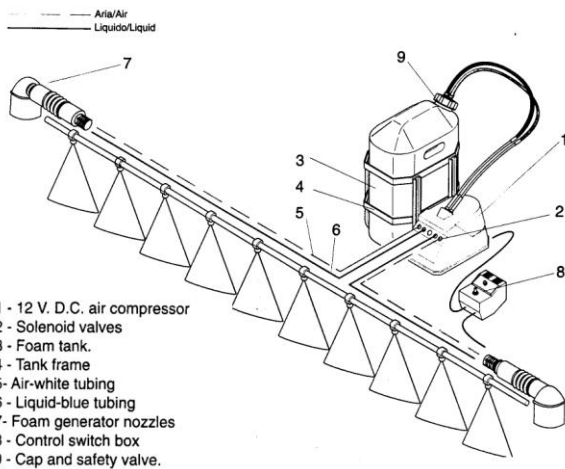

Foam markers are used to bound the ground to be processed by farm machines. They are fit to weeding machines, manure spreaders and sowing machines to prevent some areas from overlapping or not being treated. The system mixes a foaming agent with air, thus generating bubbles of white foam that fall to the ground at regular intervals marking areas that have already been processed.

## CONSTRUCTION DIAGRAM OF THE SYSTEM



## SOLENOID VALVE APPLICATION

The compressor sends compressed air to the tank containing the foaming agent, which passes to the dispenser under the effect of pressure. A battery of solenoid valves (two for the foaming agent and two for air) located on the dispenser is operated by an electrical control and allows medium and air under pressure to pass through their pipes. Foam bubbles are generated at the end of the process when air mixed with the foaming agent is ejected through the nozzles.

## SOLENOID VALVES USED

### TYPE 248



### TYPE D262



### TYPE B297



### TYPE 248

2/2 way NC direct acting solenoid valves with series 8 coils

### TYPE D262

2/2 way NC direct acting solenoid valves with series 7 coils

### TYPE B297

2/2 way NC direct acting solenoid valves with series 2 coils

## WE RECOMMEND:

The three valves proposed are all suitable for this application. The best compromise however is type 248 because:

- of its smaller overall dimensions and greater solidity as compared to type B297
- the power of series 8 coils is between series 2 and series 7
- it is cheaper than type D262.