

DD362/363 Series, Automation – Diverting 3/2 (Normally Open)

Specifications	
Function (single acting)	 <p>Flow direction OFF 1 → 3 - ON 1 → 2</p>
Maximum Viscosity	Max. 21cST (3 °E)
Body Material (Std)	Brass CW617N (EN 12165)
Orifice Material	Stainless Steel 1.4305 EN 10088 (AISI 303)
Flange	Stainless Steel 1.4305 EN 10088 (AISI 303)
Tube	Stainless Steel AISI 304
Plunger	Stainless Steel 1.4106 EN 10088 (AISI 430F)
Top Stop	Stainless Steel 1.4105 EN 10088 (AISI 430F)
Springs	Stainless Steel AISI 302
Seal Material (Std)	Foodgrade FKM
Connection Type (Std)	G parallel thread (ISO 228-1)
Shading Ring	Copper
Electrical Characteristics	
Standard Coil Voltage DC (=)	24 V
Standard Coil Voltage AC 50 Hz (-)	24 V, 110 V, 200 V, 230 V
Standard Coil Voltage AC 60 Hz (-)	24 V, 120 V, 220 V, 240 V
Voltage Tolerance	+10% to -15% (AC)
	+10% to -5% (DC)
Duty Cycle	100% ED
Protection Class	IP65 (EN 60529) with plug and gasket correctly fitted *
Electrical Connection	to EN 175301 - 803 - A (ex DIN 43650)
Coil Insulation	Class F 155 °C
Power Rating (Standard)	AC 18 VA (holding) AC 36 VA (inrush) DC 14 W

Features and Benefits

- Direct Acting
- Robust construction for industrial applications
- Zero pressure rated
- Stainless steel AISI 430F operators with low residual magnetism
- Coils tested 100% in compliance to RoHS directive and to relevant international standards
- High quality seal materials
- Response time 5 to 25 ms

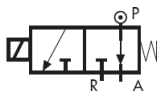

Pipe Size	Cv (gpm)	Kv (m ³ /h)	OPD (bar)		Orifice (mm)		Seal Material	Valve Code
			AC Voltages	DC Voltages	1→2	1→3		
¼"	0.09	0.08	0 - 20	0 - 20	1.5	2.5	FKM	DD363CVC
¼"	0.15	0.13	0 - 20	0 - 20	2.0	2.5	FKM	DD363CVE

Options Available

Valve Options (see coding chart)
Body threaded connection G 1/8"
NPT threads (minimum batch may be required)
Manual Override

Seal Material ¹ and Media Temperature Range	Media	Ambient Temperature Range	
		Min	Max
FKM (-10 °C to +130 °C)	Water, oil, air	-10 °C	+50 °C

¹ See corrosion reference guide and sealing solutions for material compatibility.

Coil Rotation

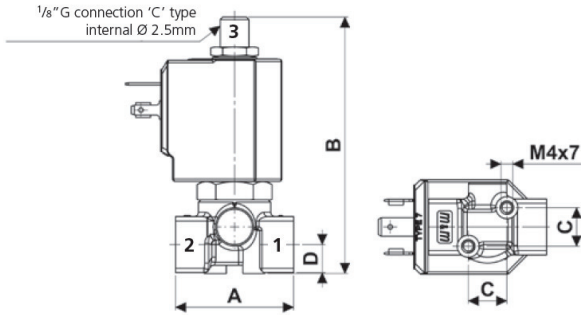

Preferred Valve Mounting Options

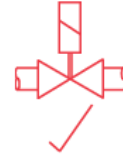

Pipe Size	A	B	C	D	Weight (kg)
1/8" - 1/4"	40	87	13	9.5	0.26

Dimensions (mm)

Solenoid enclosures

7--0 Type Coil - Insulation class F

- External material: PBT (reinforced fiberglass 30%)
- Electrical connection: DIN EN 175301-803 form A
- Winding insulation: Class H (E180)
- Enclosure classification: Conforms to IP65 (according to EN 60529) with plug and gasket correctly fitted*



Type 600 011- Plug

- Rated Voltage (max.): 250 VAC / 300 VDC
- Nominal Current: 10A (rated) / 16A (max)
- Wire cross-section: 1.5 mm² max
- Cable Entry: PG9 (6 to 8 mm)
- Enclosure classification: Conforms to IP65 (according to EN 60529) with supplied gasket
- Insulation class: group C- VDE 0110
- Housing colour: black
- UL approved, file No: E205538



* Plug and gasket not supplied as standard, must be ordered separately.

Coding chart

Main Valve Assembly

Pipe Size
2
3

Orifice
C
E

Option
N
M
w/o option

Voltage / Frequency - Class F	
7250	24 VDC
7200	24 V / 50/60 Hz
7400	110 V / 50 Hz - 120 V / 60 Hz
7600	200 V / 50 Hz - 220 V / 60 Hz
7700	230 V / 50 Hz - 240 V / 60 Hz

Plug

Plug
0A1
w/o plug

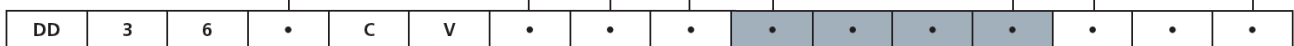

Product coding example:

DD362CVE 7250
1/8" G, auto operation, diverting, brass body, FKM seals, 2.0 mm orifice, 24 VDC, without plug.

GD362/363 Series, Automation – Universal Service 3/2 (Normally Open)

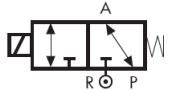
Specifications	
Function (single acting)	 <p>Pressure can be connected to any port</p>
Maximum Viscosity	Max. 21cST (3 °E)
Body Material (Std)	Brass CW617N (EN 12165)
Orifice Material	Stainless Steel 1.4305 EN 10088 (AISI 303)
Flange	Stainless Steel 1.4305 EN 10088 (AISI 303)
Tube	Stainless Steel AISI 304
Plunger	Stainless Steel 1.4106 EN 10088 (AISI 430F)
Top Stop	Stainless Steel 1.4105 EN 10088 (AISI 430F)
Springs	Stainless Steel AISI 302
Seal Material (Std)	Foodgrade FKM
Connection Type (Std)	G parallel thread (ISO 228-1)
Shading Ring	Copper
Electrical Characteristics	
Standard Coil Voltage DC (=)	24 V
Standard Coil Voltage AC 50 Hz (~)	24 V, 110 V, 200 V, 230 V
Standard Coil Voltage AC 60 Hz (~)	24 V, 120 V, 220 V, 240 V
Voltage Tolerance	+10% to -15% (AC)
	+10% to -5% (DC)
Duty Cycle	100% ED
Protection Class	IP65 (EN 60529) with plug and gasket correctly fitted *
Electrical Connection	to EN 175301 - 803 - A (ex DIN 43650)
Coil Insulation	Class F 155 °C
Power Rating (Standard)	AC 18 VA (holding) AC 36 VA (inrush) DC 14 W

Features and Benefits

- Direct Acting
- Robust construction for industrial applications
- Zero pressure rated
- Stainless steel AISI 430F operators with low residual magnetism
- Coils tested 100% in compliance to RoHS directive and to relevant international standards
- High quality seal materials
- Response time 5 to 25 ms



Pipe Size	Cv (gpm)	Kv (m ³ /h)	OPD (bar)		Orifice (mm)		Seal Material	Valve Code
			AC Voltages	DC Voltages	1→2	1→3		
¼"	0.15	0.13	0 - 8	0 - 7	2.0	2.0	FKM	GD363C/E

Options Available

Valve Options (see coding chart)
Body threaded connection G ½"
NPT threads (minimum batch may be required)

Seal Material ¹ and Media Temperature Range	Media	Ambient Temperature Range	
		Min	Max
FKM (-10 °C to +130 °C)	Water, oil, air	-10 °C	+50 °C

¹ See corrosion reference guide and sealing solutions for material compatibility.

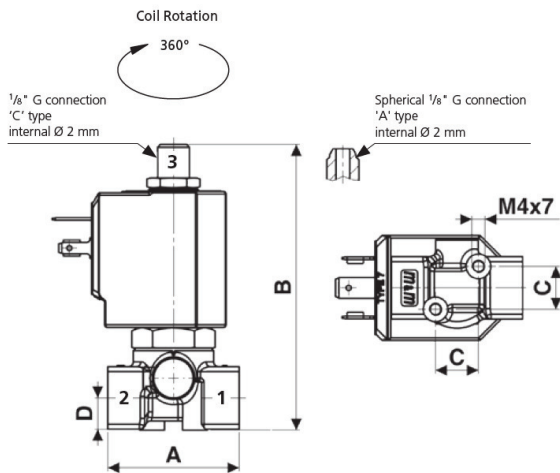

Preferred Valve Mounting Options



Pipe Size	A	B	C	D	Weight (kg)
1/8" - 1/4"	40	87	13	9.5	0.26

Dimensions (mm)

Solenoid enclosures

7--0 Type Coil - Insulation class F

- External material: PBT (reinforced fiberglass 30%)
- Electrical connection: DIN EN 175301-803 form A
- Winding insulation: Class H (E180)
- Enclosure classification: Conforms to IP65 (according to EN 60529) with plug and gasket correctly fitted*



Type 600 011- Plug

- Rated Voltage (max.): 250 VAC / 300 VDC
- Nominal Current: 10A (rated) / 16A (max)
- Wire cross-section: 1.5 mm² max
- Cable Entry: PG9 (6 to 8 mm)
- Enclosure classification: Conforms to IP65 (according to EN 60529) with supplied gasket
- Insulation class: group C- VDE 0110
- Housing colour: black
- UL approved, file No: E205538



* Plug and gasket not supplied as standard, must be ordered separately.

Coding chart

Main Valve Assembly

Pipe Size	Top Port Connection
2	1/8" C
3	1/8" A

Option
N
w/o option

Coil options

Voltage / Frequency - Class F
7250
7200
7400
7600
7700

Plug

Plug
0A1
w/o plug



Product coding example:

SD363CVE 7250
1/4" G, auto operation, universal, brass body, FKM seals, 2.0 mm orifice, with top port connection 1/8"G, 24 VDC, without plug.

SB397 Series, Automation – 2nd Service 3/2 Normally Open

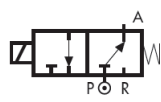
Specifications	
Function (single acting)	 <p>Flow direction OFF 3 → 1 - ON 1 → 2</p>
Maximum Viscosity	Max. 21cST (3 °E)
Body Material (Std)	Low lead content Brass CW719R (EN 12165)
Orifice Material	Stainless Steel 1.4305 EN 10088 (AISI 303)
Tube	Stainless Steel AISI 304
Flange	Stainless Steel 1.4305 EN 10088 (AISI 303)
Plunger	Stainless Steel 1.4105 EN 10088 (AISI 430F) or equivalent
Top Stop	Stainless Steel 1.4105 EN 10088 (AISI 430F)
Springs	Stainless Steel AISI 302
Seal Material (Std)	Foodgrade FKM
Connection Type (Std)	G parallel thread (ISO 228-1)
Shading Ring	Copper
Electrical Characteristics	
Standard Coil Voltage DC (=)	24 V
Standard Coil Voltage AC 50 Hz (-)	24 V, 110 V, 200 V, 230 V
Standard Coil Voltage AC 60 Hz (-)	24 V, 120 V, 220 V, 240 V
Voltage Tolerance	+10% to -15% (AC)
	+10% to -5% (DC)
Duty Cycle	100% ED
Protection Class	IP65 (EN 60529) with plug and gasket correctly fitted *
Electrical Connection	to industrial form B
Coil Insulation	Class F 155 °C
Power Rating (Standard)	AC 10 VA (holding) AC 16 VA (inrush) DC 7 W

Features and Benefits

- Direct Acting
- Robust construction for industrial applications
- Zero pressure rated
- Stainless steel AISI 430F operators with low residual magnetism
- Coils tested 100% in compliance to RoHS directive and to relevant international standards
- High quality seal materials
- Valve suitable for contact with food media as per the EEC Directives and Regulations. Please consult supplier for more details
- Response time 5 to 25 ms



Pipe Size	Cv (gpm)	Kv (m ³ /h)	OPD (bar)		Orifice (mm)		Seal Material	Valve Code
			AC Voltages	DC Voltages	1→2	1→3		
1/8"	0.05	0.04	0 - 6	0 - 3	1.2	1.7	FKM	SB397CVB
1/8"	0.07	0.06	0 - 4.5	0 - 2	1.5	1.7	FKM	SB397CVC

Options Available

Valve Options (see coding chart)
NPT threads (minimum batch may be required)
Manual Override
Electroless nickel plating treatment

Seal Material ¹ and Media Temperature Range	Media	Ambient Temperature Range	
		Min	Max
FKM (-10 °C to +130 °C)	Water, oil, air	-10 °C	+50 °C

¹ See corrosion reference guide and sealing solutions for material compatibility.

Coil Rotation



1/8" G connection 'C' type
internal Ø 1.7mm

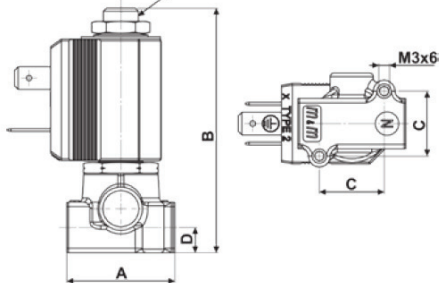

Preferred Valve Mounting Options



Pipe Size	A	B	C	D	Weight (kg)
1/8"	30	67.8	18	7	0.15

Dimensions (mm)

Solenoid enclosures

2--0 Type Coil - Insulation class F

- External material: PBT (reinforced fiberglass 30%)
- Electrical connection: Industrial form B
- Winding insulation: Class H (E180)
- Enclosure classification: Conforms to IP65 (according to EN 60529) with plug and gasket correctly fitted*



Type 600 001- Plug

- Rated Voltage (max.): 250 vAC / 300 vDC
- Nominal Current: 10A (rated) / 16A (max)
- Wire cross-section: 1.5 mm² max
- Cable Entry: PG9 (6 to 8mm)
- Enclosure classification: Conforms to IP65 (according to EN 60529) with supplied gasket
- Insulation class: group C- VDE 0110
- Housing colour: black
- UL approved, file No: E205538



* Plug and gasket not supplied as standard, must be ordered separately.

Coding chart

Main Valve Assembly

Coil options

Plug

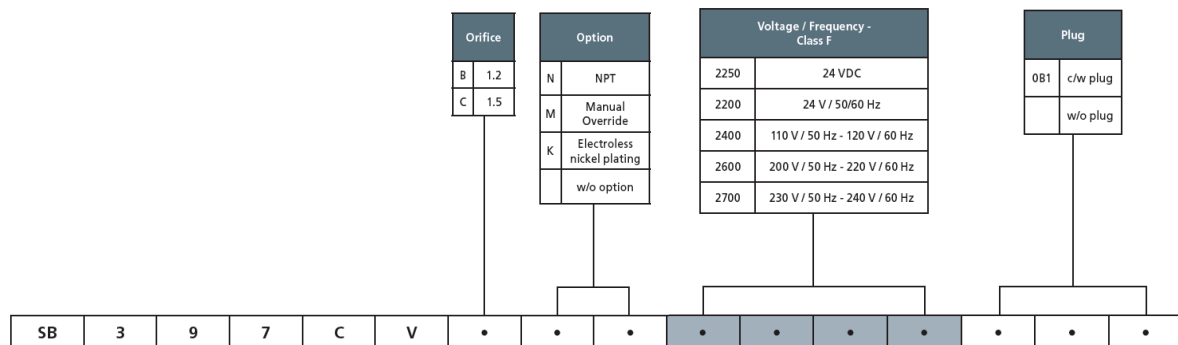

Product coding example:

SB397CVB 2250
1/8" G, auto operation, brass body, FKM seals, 1.2 mm orifice, with manual override, 24 VDC, without plug.

SD362/363 Series, Automation – 2nd Service 3/2 (Normally Open)

Specifications	
Function (single acting)	 <p>Flow direction OFF 3 → 1 - ON 1 → 2</p>
Maximum Viscosity	Max. 21cST (3 °E)
Body Material (Std)	Brass CW617N (EN 12165)
Orifice Material	Stainless Steel 1.4305 EN 10088 (AISI 303)
Flange	Stainless Steel 1.4305 EN 10088 (AISI 303)
Tube	Stainless Steel AISI 304
Plunger	Stainless Steel 1.4106 EN 10088 (AISI 430F)
Top Stop	Stainless Steel 1.4105 EN 10088 (AISI 430F)
Springs	Stainless Steel AISI 302
Seal Material (Std)	Foodgrade FKM
Connection Type (Std)	G parallel thread (ISO 228-1)
Shading Ring	Copper
Electrical Characteristics	
Standard Coil Voltage DC (=)	24 V
Standard Coil Voltage AC 50 Hz (-)	24 V, 110 V, 200 V, 230 V
Standard Coil Voltage AC 60 Hz (-)	24 V, 120 V, 220 V, 240 V
Voltage Tolerance	+10% to -15% (AC)
	+10% to -5% (DC)
Duty Cycle	100% ED
Protection Class	IP65 (EN 60529) with plug and gasket correctly fitted *
Electrical Connection	to EN 175301 - 803 - A (ex DIN 43650)
Coil Insulation	Class F 155 °C
Power Rating (Standard)	AC 18 VA (holding) AC 36 VA (inrush) DC 14 W

Features and Benefits

- Direct Acting
- Robust construction for industrial applications
- Zero pressure rated
- Stainless steel AISI 430F operators with low residual magnetism
- Coils tested 100% in compliance to RoHS directive and to relevant international standards
- High quality seal materials
- Response time 5 to 25 ms



Pipe Size	Cv (gpm)	Kv (m ³ /h)	OPD (bar)		Orifice (mm)		Seal Material	Valve Code
			AC Voltages	DC Voltages	1→2	1→3		
¼"	0.09	0.08	0 - 15	0 - 15	1.5	1.5	FKM	SD363CVC
¼"	0.15	0.13	0 - 15	0 - 15	2.0	2.0	FKM	SD363CVE
¼"	0.24	0.20	0 - 13	0 - 13	2.5	2.5	FKM	SD363CVG

Options Available

Valve Options (see coding chart)
Body threaded connection G 1/8"
NPT threads (minimum batch may be required)
Manual Override

Seal Material ¹ and Media Temperature Range	Media	Ambient Temperature Range	
		Min	Max
FKM (-10 °C to +130 °C)	Water, oil, air	-10 °C	+50 °C

¹ See corrosion reference guide and sealing solutions for material compatibility.

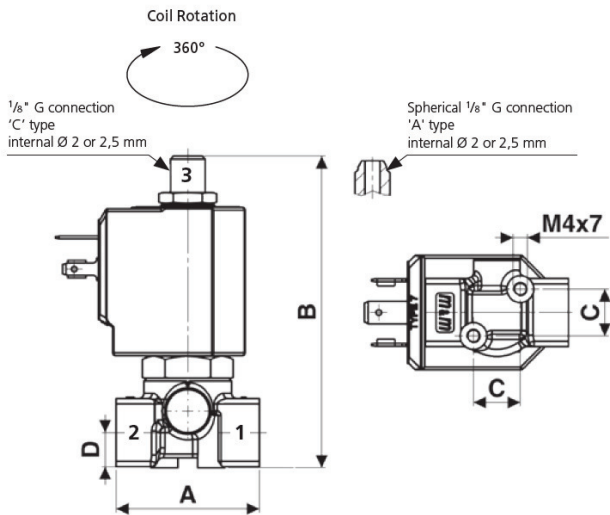

Preferred Valve Mounting Options



Pipe Size	A	B	C	D	Weight (kg)
1/8" - 1/4"	40	87	13	9.5	0.26

Dimensions (mm)

Solenoid enclosures

7--0 Type Coil - Insulation class F

- External material: PBT (reinforced fiberglass 30%)
- Electrical connection: DIN EN 175301-803 form A
- Winding insulation: Class H (E180)
- Enclosure classification: Conforms to IP65 (according to EN 60529) with plug and gasket correctly fitted*



Type 600 011- Plug

- Rated Voltage (max.): 250 VAC / 300 VDC
- Nominal Current: 10A (rated) / 16A (max)
- Wire cross-section: 1.5 mm² max
- Cable Entry: PG9 (6 to 8 mm)
- Enclosure classification: Conforms to IP65 (according to EN 60529) with supplied gasket
- Insulation class: group C- VDE 0110
- Housing colour: black
- UL approved, file No: E205538



* Plug and gasket not supplied as standard, must be ordered separately.

Coding chart

Main Valve Assembly

Pipe Size	Top port connection
2 1/8"	C 1/8" G
3 1/4"	A spherical 1/8" G

Orifice	Option
C 1.5	N NPT
E 2.0	M Manual Override
G 2.5	w/o option

Coil options

Voltage / Frequency - Class F	
7250	24 VDC
7200	24 V / 50/60 Hz
7400	110 V / 50 Hz - 120 V / 60 Hz
7600	200 V / 50 Hz - 220 V / 60 Hz
7700	230 V / 50 Hz - 240 V / 60 Hz

Plug

Plug
0A1 c/w plug
w/o plug



Product coding example:

SD362AVG 7400
1/8" G, auto operation, 2nd service, brass body, FKM seals, 2.5 mm orifice, with top port connection spherical 1/8" G, 110 V / 50 Hz - 120 V / 60 Hz, without plug.