

# Air Compressors

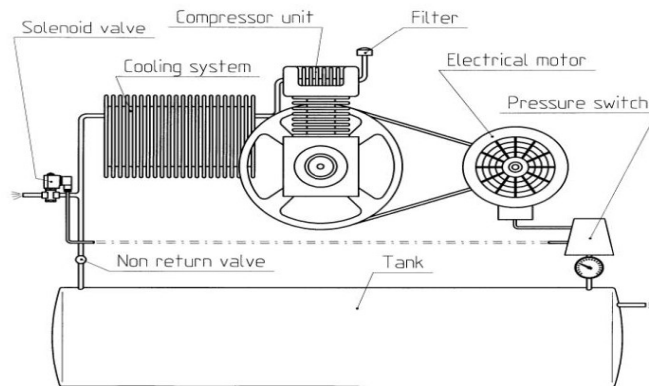

Machine used for the production of compressed air. It consists of a piston compressor with power supplied by an electric motor, a refrigerator and a tank. Its working principle is air compression: air is taken from the atmosphere, compressed by the compressor and collected into a tank. A filter is fitted at the intake to prevent foreign particles from going into the cylinder head. A cooling coil removes the condensate created by the heating of compressed air.

## Construction Diagram Of The System



## Solenoid Valve Application

When the system is operating, the electric motor runs the compressor, which takes in filtered air, compresses it, sends it to the refrigerator and finally to the tank. During this stage the solenoid valve is energized and closes the circuit keeping it under pressure. When the tank reaches the requested pressure reading, a pressure switch stops the motor and the check valve keeps air inside the tank. To prevent the compressor from remaining under pressure for too long and so getting damaged, the solenoid valve is then de-energized, and it allows exceeding air still in the circuit to be exhausted.

## Solenoid Valves Used

TYPE RD236



TYPE RB214



TYPE RB203



Type RD236 with series 7 coils  
2/2 way NO direct acting solenoid valve

Type RB214 with series 2 coils  
2/2 way NO direct acting solenoid valve

Type RB203 with series 2 coils  
2/2 way NO pilot operated solenoid valve

## We Recommend

In this application it is necessary that the solenoid valve is in the normally open (NO) working condition. For small flow rates direct acting types RD236 (connection 1/4") and RB214 are certainly recommended because they were expressly created for the normally open operation. For large flow rates the use of pilot operated solenoid valves like type RB203 (with commercial connection 3/8") are recommended.